

# **Choice Framework for local Policy and Procedures 01-06 – Decontamination of flexible endoscopes: Design and installation**

**Choice Framework for local Policy and  
Procedures (CFPP) 01-06  
Decontamination of flexible endoscopes:  
Design and installation**

© Crown copyright 2013

Terms of use for this guidance can be found at <http://www.nationalarchives.gov.uk/doc/open-government-licence/>

# Preface

## Introduction

The Choice Framework for local Policy and Procedures (CFPP) is an initiative being piloted by the Department of Health.

It forms a suite of evidence-based policy and guidance documents on the management and decontamination of reusable medical devices.

## Purpose

The purpose of CFPP is to enable local choices to be made regarding the management, use and decontamination of reusable medical devices at controlled costs using risk control.

CFPP is designed to reflect the need to continuously improve outcomes in terms of:

- patient safety;
- clinical effectiveness; and
- patient experience.

## Essential Quality Requirements and Best Practice

The Health Act Code of Practice recommends that healthcare organisations comply with guidance establishing Essential Quality Requirements and demonstrate that a plan is in place for progression to Best Practice.

Essential Quality Requirements (EQR), for the purposes of this best practice guidance, is a term that encompasses all existing statutory and regulatory requirements. EQRs incorporate requirements of the current Medical Devices

Directive and Approved Codes of Practice as well as relevant applicable Standards. They will help to demonstrate that an acute provider operates safely with respect to its decontamination services.

Local policy should define how a provider achieves risk control and what plan is in place to work towards Best Practice.

Best Practice is additional to EQR. Best Practice as defined in this guidance covers non-mandatory policies and procedures that aim to further minimise risks to patients; deliver better patient outcomes; promote and encourage innovation and choice; and achieve cost efficiencies.

Best Practice should be considered when developing local policies and procedures based on the risk of surgical procedures and available evidence. Best Practice encompasses guidance on the whole of the decontamination cycle, including, for example, improved instrument management, where there is evidence that these procedures will contribute to improved clinical outcomes.

The CFPP suite is listed below.

- Choice Framework for local Policy and Procedures 01-01: Management and decontamination of surgical instruments (medical devices) used in acute care
- Choice Framework for local Policy and Procedures 01-04: Decontamination of linen for health and social care
- Choice Framework for local Policy and Procedures 01-06: Decontamination of flexible endoscopes

# Abbreviations

**AE(D):** Authorising Engineer (Decontamination)

**CP(D):** Competent Person (Decontamination)

**EN:** European Norm

**EWD:** endoscope washer-disinfector

**ISO:** International Standards Organisation

**PPE:** personal protective equipment

**RO:** reverse osmosis

**TOC:** total organic carbon

**TVC:** total viable count

# Executive summary

Choice Framework for local Policy and Procedures (CFPP) 01-06 offers best practice guidance on the management and decontamination of flexible endoscopes (principally gastrointestinal scopes and bronchoscopes). It also aims to support commissioners and providers in implementing appropriate and effective decontamination measures to reduce the risks of person-to-person transmission of human prion diseases.

For an introduction to the CFPP framework, please see 'Choice Framework for local Policy and Procedures'.

## Scope

This document covers flexible endoscope management and decontamination only. Clinical issues relating to endoscopy or the manufacture of EWDs are not discussed. In addition this document does not cover the processing of flexible endoscopes used to examine sterile body tissues. These endoscopes should be sterile, possibly using low temperature gas sterilization, and may be the subject of future guidance.

## Structure

CFPP 01-06 is divided into five volumes:

- The 'Policy and management' volume sets the Department of Health's (DH) policy context and

discusses the Essential Quality Requirements and Best Practice recommendations for an endoscope decontamination service. Transmissible spongiform encephalopathy (TSE) infectious agents are discussed and guidance given on management and handling of an endoscope after it has been used on a patient at increased risk of vCJD.

- The 'Design and installation' volume gives guidance on the design and fitting of endoscope reprocessing units.
- The 'Operational management' volume gives guidance on operational responsibility together with advice on the procurement and operation of an endoscope washer-disinfector (EWD).
- The 'Validation and verification' volume highlights the types of tests and maintenance procedures that are needed to ensure that decontamination has been achieved.
- The 'Testing methods' volume discusses the principles and methods that are used in the tests described in this CFPP and the tests detailed in BS EN ISO 15883-4.

CFPP 01-06 supersedes the relevant parts of Health Technical Memorandum 2030 dealing with endoscope decontamination.



# Contents

Preface	
Abbreviations	
Executive summary	
	Introduction
	Purpose
	Essential Quality Requirements and Best Practice
	Scope
	Structure
<b>1 Design of an endoscope reprocessing unit</b>	<b>1</b>
	Introduction
	Layout of the unit
	Single-room decontamination area
	Siting of EWDs
	Wash room
	Decontaminated equipment room
	Transport and storage of decontaminated endoscopes
	Example layouts
	Design of an endoscope reprocessing unit for a local unit or small hospital
	Access to engineering services
<b>2 Water quality and water treatment</b>	<b>11</b>
	Water quality
	Initial and intermediate rinse stages
	Final rinse-water
	Chemical process residues
	Water used to dilute chemicals
	Key factors affecting the quality of water
	Water hardness
	Temperature
	Ionic contaminants
	Microbial contamination
	Deposits from water
	Bacterial endotoxins
	Total organic carbon (TOC)
	Legionella and <i>Pseudomonas aeruginosa</i>
	Water treatment options
	Water softeners
	Water deionisers
	Distillation
	Reverse osmosis (RO)
	Filtration
	Disinfectant addition
	Water treatment plant
	Tests for purity levels
	Chemical purity



	Organic purity	
	Microbial purity	
	Pipework	
	Biofilm formation	
	Water supply regulations and services	
<b>3 Engineering services</b>		<b>20</b>
	Summary for commissioners and quality inspectors	
	Ancillary equipment	
	Water services	
	Electrical services	
	Drainage	
	Hazardous effluents	
	Ventilation	
	General room ventilation	
	EWD ventilation	
	Chemical additives	
	Infectious materials	
	Engineering services checklist	
<b>References</b>		<b>25</b>

# 1 Design of an endoscope reprocessing unit

## Summary for commissioners and quality inspectors

This chapter gives guidance on the design and fitting of endoscope reprocessing units, small and large. A list of development stages when designing a new department is provided. Guidance layouts are included together with a checklist of engineering requirements. In addition, information is given on how the workflow will influence unit design to provide a good working area for staff.

Quality inspectors will find the guidance provided here of value in assessing the suitability of units for reprocessing operations to the Essential Quality Requirements level or a plane to progress to Best Practice.

See 'Essential Quality Requirements and Best Practice' in the 'Policy and management' volume.

## Introduction

- 1.1 Suitable decontamination facilities should exist on all sites where flexible endoscopy is carried out. Constraints, such as space, may well require that decontamination is not carried out in the endoscopy unit, but elsewhere on the same site.
- 1.2 The approach to the design of an endoscope reprocessing unit will depend on its likely size and the number of procedures to be performed per week. The requirements for a large unit contained in a general hospital will be significantly different from those in a small endoscopy unit forming part of a community hospital or independent hospital. However, regardless of size or clinical role, the primary aim is to ensure an environment in which successful risk control is achieved in the management and decontamination of endoscopes (see Figure 1).

Figure 1 Design examples for an endoscope reprocessing unit

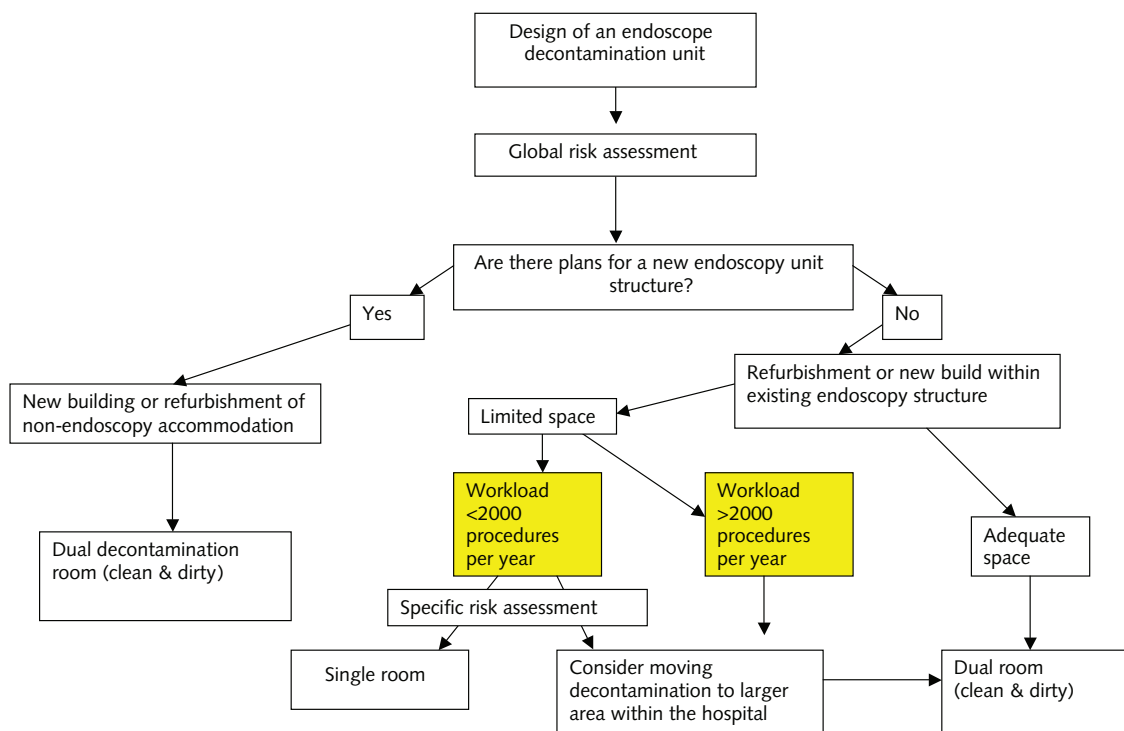

1.3 The development of a small or large endoscopy unit is likely to follow the same pattern in the initial stages. Table 1 provides a list of possible development stages. An Authorising Engineer (Decontamination) (AE(D)) will be able to provide advice on the design of an endoscope reprocessing unit.

**Table 1 Stages of development for an endoscopy unit**

1	Determine patient throughput now and for the future (for example, over the next five years with due regard to the care pathways and quality standards in use).
2	Endoscope reprocessing units should have in place the medical devices quality management system BS EN ISO 13485 and operate in a manner consistent with the Medical Devices Regulations. This may be addressed by the use of double-ended endoscope washer-disinfectors (EWDs) with separate clean and dirty rooms (two-room option). Where this approach is not available, single-ended EWDs should be used with separation of clean and dirty areas.
3	Determine how dirty endoscopes are to enter the decontamination room and how clean endoscopes are returned to the operating room without possible contamination transfer.
4	Work out the number of EWDs required to process the endoscopes used within the unit's opening time. The cycle process time should be considered when new EWD designs are purchased to allow the calculation of how many endoscopes can be processed in a day. Allow for 60% usage time.
5	The design of the EWD will affect the number of endoscopes able to be processed per day. Machines with shared chambers may require that two endoscopes are ready for processing at the same time. EWDs with separate independent chambers allow the reprocessing of endoscopes to be staggered, making better use of the facilities (see 'Choice and procurement of an EWD' in the 'Operational management' volume).
6	Determine how many clinics/wards/theatres are to be served and their location: local or distant.
7	If some clinics are distant from the decontamination room, a transport system will be required. This may consist of trolleys and covered trays to transport endoscopes; parking areas for the trolleys; and a means of preventing dirty endoscopes contaminating cleaned endoscopes. Determine how trolleys and transport containers, if used, are to be decontaminated (see Health Building Note 13).
8	Analyse the planned unit's water quality based on the data over 12 months (may be available from the local water authority). See <a href="#">Chapter 2, 'Water quality and water treatment'</a> .
9	Determine whether the existing hot and cold water system in the hospital is capable of supplying the new unit, without starving any other department in the hospital of their supplies (this could have legionellae implications). In addition, stagnation in a plumbing system could lead to legionellae colonisation (see Chapter 2, 'Water quality and water treatment').
10	Decide on the water treatment required for the final rinse and possibly the chemical-diluting water. See Chapter 2, 'Water quality and water treatment'.
11	Determine if the water treatment plant and water storage is to be housed within the endoscopy unit or sited elsewhere. If within the unit, where will it be sited? See Chapter 2, 'Water quality and water treatment'.
12	Determine the needs for manual cleaning (for example, number of sinks, bench area etc. Health Building Note 13 contains useful advice).
13	Determine the storage requirements for supplies and equipment. This is particularly important for the process chemicals that may be hazardous in concentrated form (see 'Process chemicals' in the 'Operational management' volume).
14	Decide on how reprocessed endoscopes are to be stored. If storage cabinets are to be used, how many and where they are to be sited (see 'Cycle of use and decontamination of endoscopes' in the 'Operational management' volume)?
15	Sketch out a layout to scale; include the largest EWDs and storage cabinet footprints. See <a href="#">Figures 2–5</a> in 'Example layouts'.
16	Determine the IT requirements, including the traceability system. How many workstations, printers etc will be required? Tracking and traceability guidance is given in 'Tracking, traceability and audit trail' in the 'Operational management' volume.
17	Determine which, if any, medical gases are required within the unit. This evaluation should give careful consideration to the need for medical oxygen. If the EWD does not have its own clean air supply for drying reprocessed endoscopes, this may need to be supplied from a separate unit or a medical gas supply. The manual cleaning protocol may require the use of compressed air or vacuum; the drying cabinet may require compressed air. Where medical gases are identified as necessary, the advice of the Authorising Engineer (Medical Gas Pipeline Systems) should be consulted.

- |    |  |
|----|--|
| 18 | Calculate the ventilation requirements. If the endoscope decontamination area is divided into clean and dirty areas, the ventilation system should be designed to the recommendations given in Appendix 2 of Health Technical Memorandum 03-01, Part A. Carry out an appropriate risk assessment for the treatment room (for example, tuberculosis risk), taking account of the air-change rates for treatment rooms and wash rooms. In addition, determine the space required for ductwork and the correct positioning of supply and extract air diffusers. |
| 19 | Determine where the air-handling unit for the department will be sited.  |
| 20 | Include in the plan access to patient areas, changing-room facilities, staff rest rooms and changing rooms. Allow space for the cleaners' cupboard, particularly for the wash room.  |
| 21 | To assist planning, to obtain guidance including the specification of equipment, consult with a member of a qualified body, such as an AE(D), or the estates/facilities departments of the qualified healthcare provider.  |
- 1.4 In accordance with the 'Health and Social Care Act 2008: Code of Practice on the prevention and control of infections and related guidance', standards of cleanliness are important to the maintenance of high attainment in the endoscope management and reprocessing service. All areas used as part of this process should be subject to basic visual scrutiny at reasonable intervals. It is important to ensure that the equipment necessary to support cleanliness is available and accessible from all of the areas where endoscope reprocessing takes place. The availability of separate sinks and wash-hand basins for use by staff is an important consideration. The Director of Infection Prevention and Control (DIPC)/infection control team should be consulted on the attainment and maintenance of general hygiene standards.
- 1.5 Preferably, endoscopes should not be transported between hospitals for decontamination. Where routine operation or contingency planning requires the transport of endoscopes between hospitals or centres, a risk assessment should be undertaken to consider all the factors that may affect the transport of clean reprocessed endoscopes and those that will affect the handling of dirty returned endoscopes. The conditions of the Carriage of Dangerous Goods and Use of Transportable Pressure Equipment Regulations 2009 will need to be considered when dirty endoscopes are transported by a third-party carrier. Procedures and equipment used in transport should be such as to provide for effective prevention of infection with particular

attention to the separation of clean and dirty equipment.

- 1.6 Provision may be made within an operating department, under exceptional circumstances, for an endoscope decontamination facility to reprocess those endoscopes that cannot be returned to the central decontamination area. This should be provided in a room dedicated for this purpose with manual cleaning facilities and an EWD. The standard of decontamination should be the same as that carried out in a dedicated endoscopy unit. In addition, staff training should be similar to the training obtainable in the main endoscopy unit. The management of such a unit should be to a similar standard as for a central endoscopy decontamination department.

## Layout of the unit

- 1.7 It is important to ensure that the workflow within the department is from dirty to clean to avoid the possibility of recontamination of reprocessed endoscopes from surfaces contaminated by unprocessed devices.

## Single-room decontamination area

- 1.8 The decontamination room should have two entrances/exits. These may be in the form of hatches for the endoscopes and a door for staff:
- one hatch or door used for dirty endoscopes returning from the treatment area; and
  - one hatch or door for the delivery of reprocessed clean endoscopes for the next procedure.
- 1.9 Facilities should be provided for convenient access to the traceability system so the endoscope data can be entered onto the database.
- 1.10 **Figure 2** in 'Example layouts' illustrates a single room decontamination unit serving more than one theatre.
- 1.11 A flow of work can be based on the process described in 'Cycle of use and decontamination of endoscopes' (in the 'Operational management' volume).
- 1.12 The layout of equipment in the decontamination room should be based on carrying out the above procedure without crossover or recontamination of reprocessed endoscopes.
- 1.13 In addition to endoscope decontamination, the decontamination of trays or use of disposable liners

is recommended. In addition, transport trolleys should be considered for decontamination as necessary. This should be considered as part of operational risk assessment.

- 1.14 In addition to the operating time of an EWD, the testing and service time should be factored into the calculation. Weekly testing will take up the time of at least one cycle. The periodic tests performed to Table 5 in the 'Validation and verification' volume will involve the loss of use of the EWD for up to one day for quarterly and several days for annual validation.
- 1.15 Spare EWD capacity will be required to allow for maintenance and breakdown. It is recommended that machines should be used alternatively and not be allowed to lie idle. EWDs do not provide a reliable service if left idle for days or weeks, as biofilm will grow in internal tubes and valves. In addition, tubes containing chemicals may drain; so the first cycle of use after a rest period may not take up the correct volume of fluids. As a minimum, the EWD should operate on a self-disinfection cycle daily.

### Siting of EWDs

- 1.16 The position of the EWD is a key decision to be made when designing a decontamination room, as it may determine the size of the room, the position of other facilities and engineering considerations (see Chapter 3, 'Engineering services' and Table 2 in 'Access to engineering services'). If an endoscope reprocessing unit is to be built or refurbished, two rooms and double-ended EWDs are the preferred option and may be locally risk-assessed as Best Practice.
- 1.17 The room in which an EWD is installed and operated should meet the requirements of the Workplace (Health, Safety and Welfare) Regulations. These regulations have considerable implications for the accommodation of EWDs.
- 1.18 Fire safety precautions should comply with Approved Document B – 'Fire safety', which accompanies the Building Regulations 2000 (as amended), and Health Technical Memorandum 05-03 Part A – 'General fire safety'.

### Wash room

- 1.19 The wash room provides space to:
- off-load soiled returns from trolleys;

The soiled returns hold area, where collection trolleys containing soiled returns can be stored, is normally located adjacent to or within the washing area and adjacent, or with easy access, to the hospital corridor or loading bay.

- clean transport trolleys, if used. These trolleys and associated trays should be made of a cleanable material and tray liners should be used so that endoscopes do not come in direct contact with the trolleys and trays.
  - sort items for disposal or appropriate cleaning and disinfection;
  - clean and disinfect items able to be reprocessed;
- 1.20 The storage of PPE and hand-washing facilities should be provided.
- 1.21 Manual cleaning facilities will also be required with the following requirements:
- a stainless steel double sink designed to wash flexible endoscopes with:
    - (i) a convenient depth to allow complete immersion of endoscopes;
    - (ii) adequate size and base area;
    - (iii) double drainer;
    - (iv) Care should be taken to ensure that an ergonomic assessment is undertaken and that the protection of the health and safety of staff operatives of variable stature or height is considered. Where variable height sinks are used, the possibility of trapping hazards should be recognised and appropriately controlled.

### Note

Sinks used for manual cleaning should be supplied with water directly from the main supply if possible. Tank water can often be contaminated and the cleaned endoscopes will then contain bioburden from retained water. Branches and dead legs in the supply system will also allow biofilm to form in the pipes. The use of jet washer is discouraged. If the sink is fitted with a rinse recirculating system for flushing lumens, it should be disinfected before use and drained dry when not in use. The disinfection procedure given by the sink manufacturer will need to be followed.

- a range of brushes available to suit the type of endoscopes being cleaned.

- guidance procedure for the Operator giving details relating to the different types of endoscope being reprocessed and suitable brushing techniques.

### Decontaminated equipment room

- 1.22 The decontaminated equipment room is sited on the clean side of the EWD and should have a separate staff access to the dirty area. In larger units with separate clean and dirty rooms, endoscopes should not pass into the decontaminated equipment room unless they have passed through the EWD.
- 1.23 The decontaminated equipment room may house drying cabinets and, if required, clean transport trolleys for the distribution of reprocessed endoscopes in protective wraps (see 'Cycle of use and decontamination of endoscopes' in the 'Operational management' volume).

#### Note

If there is no separate decontaminated equipment room, the transfer of cleaned and disinfected items to the endoscope storage facility should take place without crossing the path of soiled instruments.

### Transport and storage of decontaminated endoscopes

- 1.24 In a small endoscopy unit, it is likely that reprocessed endoscopes will be used directly after they have been cleaned in an adjacent room, or they will be stored for the next clinic. Where the transfer of endoscopes to another department occurs, consideration should be given to the transport system and the method of carrying endoscopes during transit (see the 'Packaging and transport' section in 'Cycle of use and decontamination of endoscopes' (in the 'Operational management' volume)).

### Example layouts

- 1.25 The example layouts in this section show the concepts that are important in endoscope decontamination room design. They are not intended to be specific room layouts, and variations incorporating the design philosophy are acceptable.
- 1.26 Room layouts are intended to support good decontamination practice by trained operators.

- 1.27 If operational practices require endoscopes to be stored for extended periods after decontamination, endoscope drying cabinets should be considered. If endoscopes are to be used soon after decontamination, non-drying storage cabinets will be more appropriate (see 'EWD operation, and endoscope storage and transport' in the 'Operational management' volume).
- 1.28 Many of the procedures carried out within these facilities are demanding in terms of clear sight of small components, fittings, accessories and visible contamination. This will require careful attention to the design of a lighting strategy consisting of lighting utilising diffusers where appropriate and supported by task lighting for the detailed observation of endoscopes and associated equipment (see CIBSE's (2008) LG2 – 'Lighting for hospitals and healthcare buildings').
- 1.29 Surfaces in contact with endoscopes and their components or those likely to be contaminated should be impervious, easily cleaned and be able to withstand disinfection (see Health Facilities Note 30 – 'Infection control in the built environment' and Health Building Note 00-10 Parts A – 'Flooring', B – 'Walls and ceilings' and C – 'Sanitary assemblies').
- 1.30 As shown in **Figure 2**, there must be a clearly designated flow from dirty to decontaminated such that there can never be uncertainty about which stage of decontamination an endoscope has reached as it progresses from dirty to clean. A risk assessment should be used to support the design process and further determine whether there is a probable future need for separate clean and dirty rooms. Regardless of the design option chosen, it is essential that the room floor area be adequate to support the full process of endoscope management and decontamination without compromising quality. While it is acceptable for units to depend on a single EWD in terms of decontamination quality, the operational implications of breakdown and maintenance should be carefully considered.
- 1.31 **Figure 3a** makes use of a single-ended EWD(s) but with a clearly designated flow from dirty to decontaminated endoscopes such that there can never be uncertainty about which stage of decontamination an endoscope has reached as it progresses from dirty to clean.
- 1.32 **Figure 3b** uses double-ended EWD(s) and may be preferred if a risk assessment indicates this requirement.

Figure 2 Example schematics of single-room decontamination unit for low throughput units

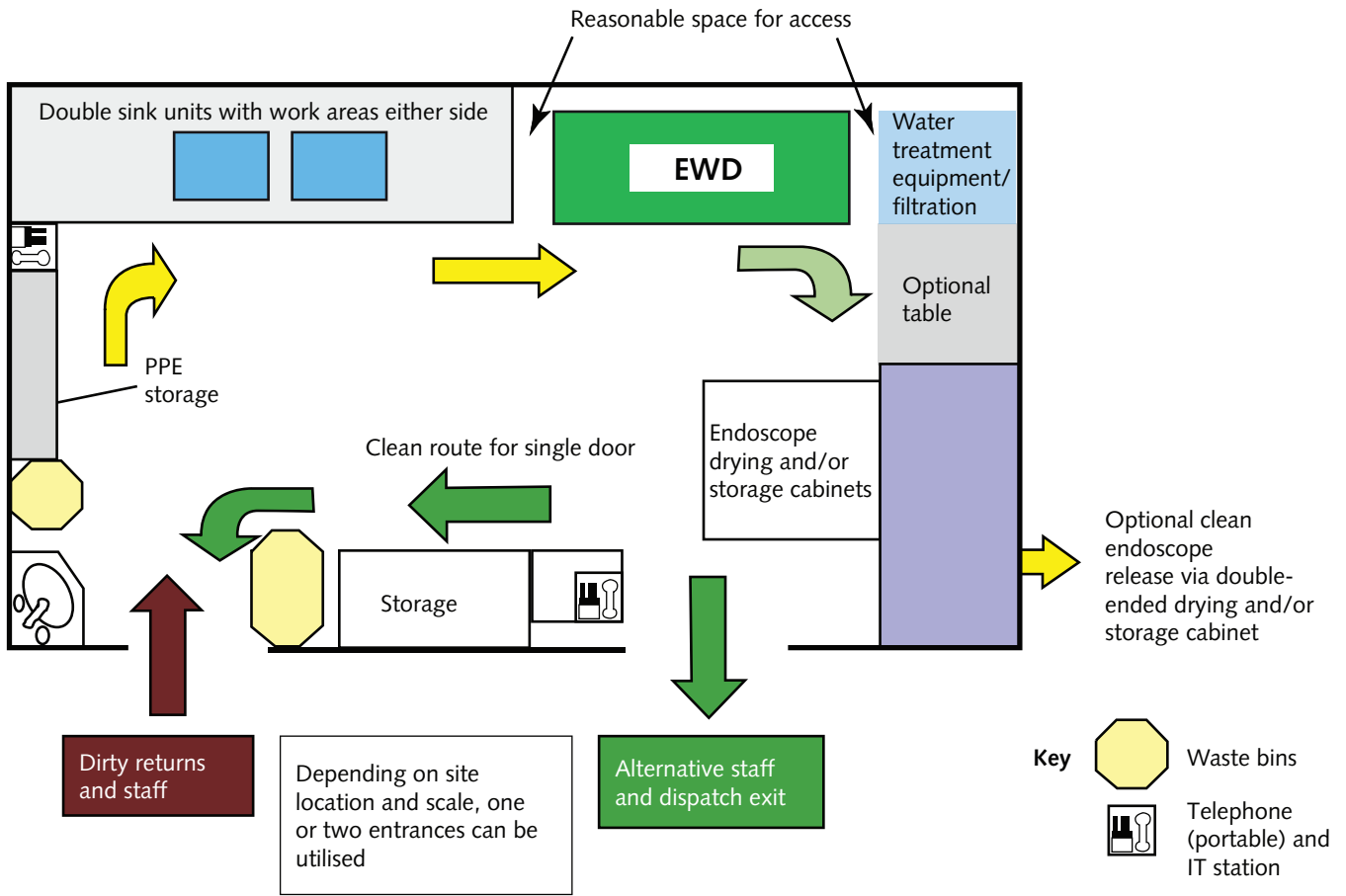

Figure 3a Example schematic of a large room with single-ended EWDs

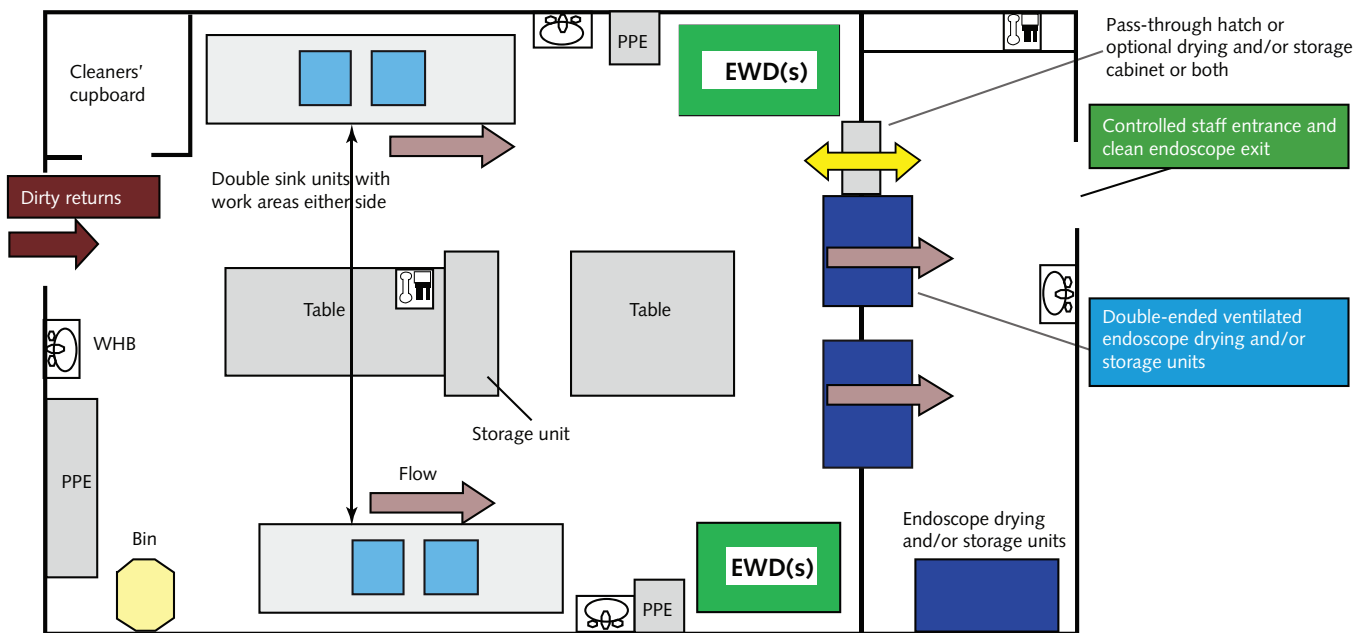
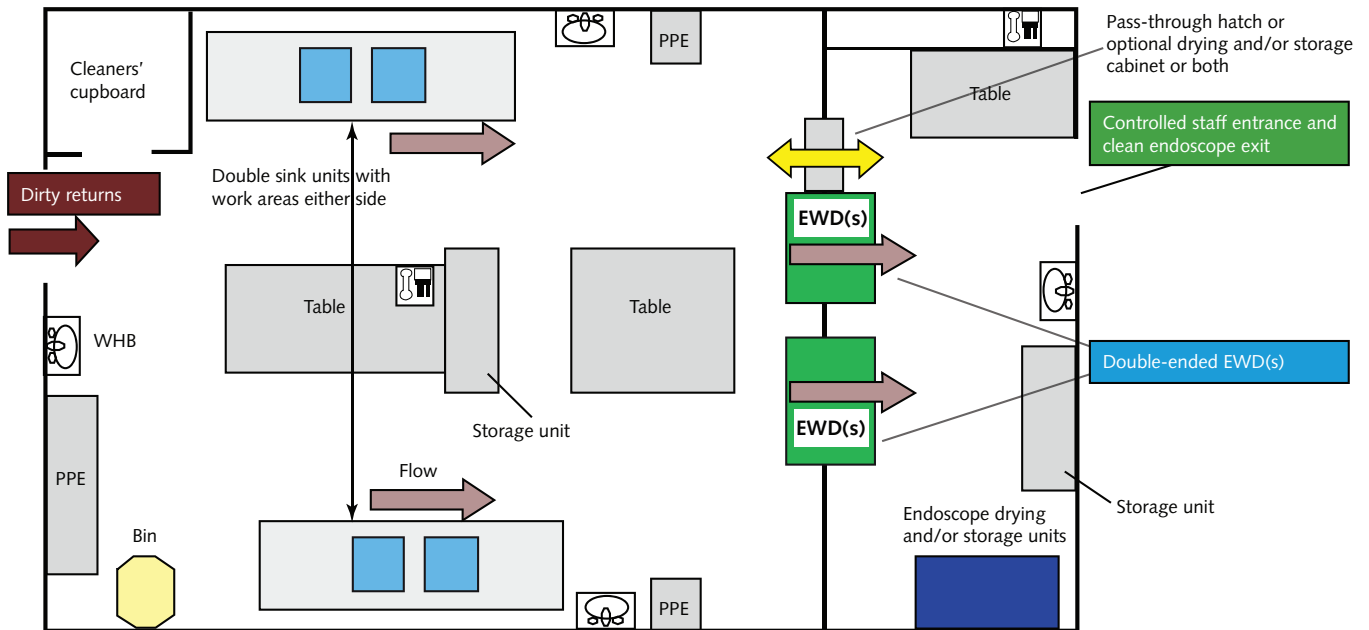

Figure 3b Two-room decontamination unit using double-ended EWDs



1.33 The unit shown in Figure 4, particularly if used as the centralised endoscope decontamination facility, represents progress towards Best Practice. It is divided into three sections: endoscope cleaning areas, decontaminated equipment area and drying or storage and despatch area. Double-ended EWD(s) and double-ended drying and/or storage cabinets are illustrated, but single-ended dryers or storage cabinets could be used as an alternative. The unit includes areas for staff to put on appropriate personal protective equipment (PPE)

for dirty and separately for clean areas, adding to the effective separation of these areas.

1.34 The example in Figure 5 is specifically designed with adjacent treatment areas attached to the decontamination unit. This design concept can be adapted to serve more than two adjacent treatment rooms. The design should take account of the need to ensure that used endoscope input to the decontamination area is such that the decontamination status of clean, reprocessed endoscopes is not compromised.

Figure 4 High throughput reprocessing unit

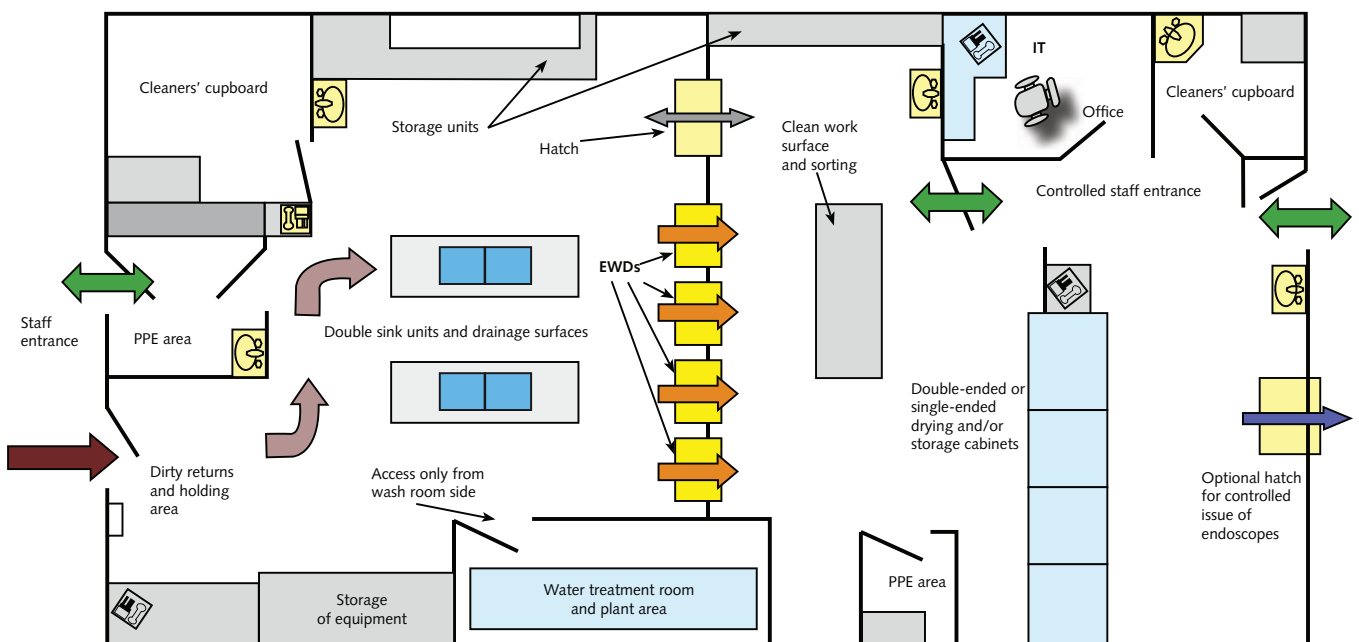
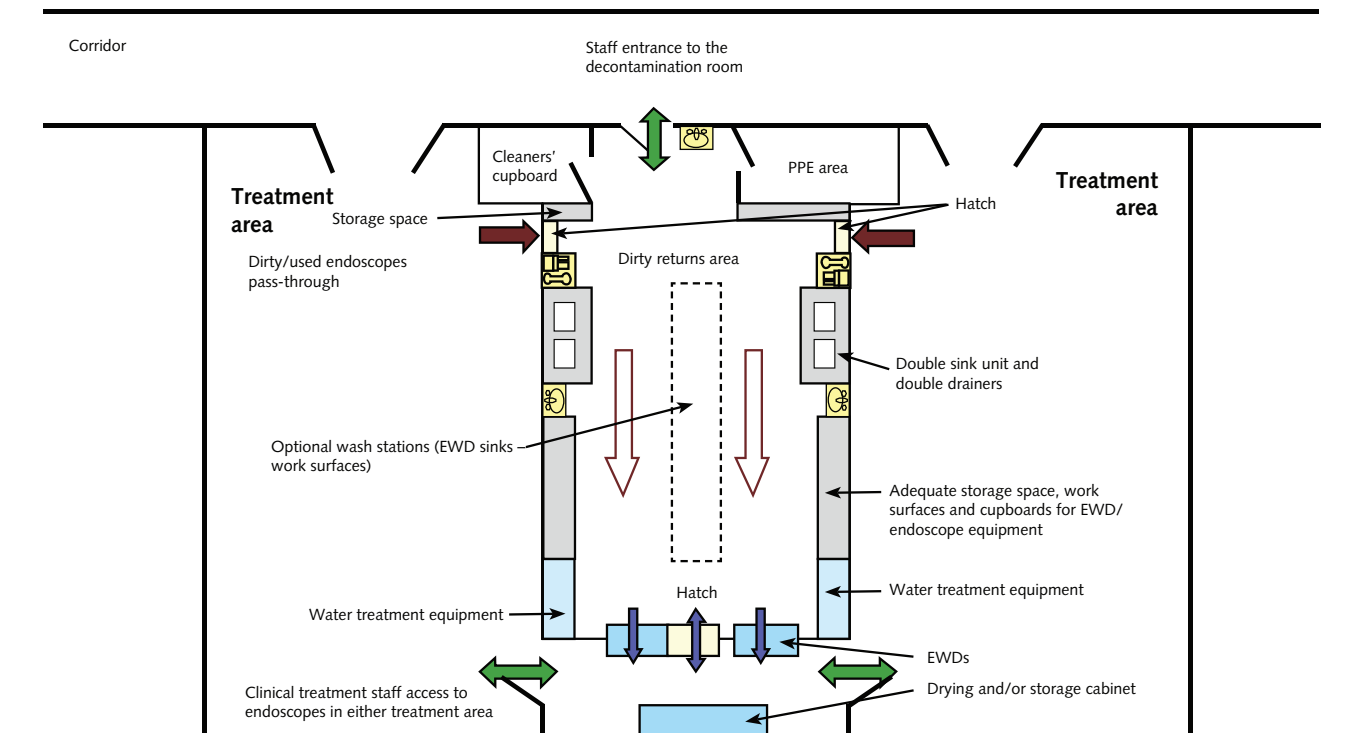



Figure 5 Reprocessing unit supplying adjacent treatment rooms



1.35 The size of the decontamination area will be determined by the demands, number and nature of procedures undertaken in the treatment rooms. The unit includes double-ended EWD(s) and appropriate drying or storage cabinet facilities, but, provided there is a clear flow from dirty to clean, single-ended EWDs can be used.

1.36 The drying cabinet capacity may need to accommodate all the available endoscopes for overnight storage if operational requirements so demand, (that is, if reprocessing endoscopes the next morning after storage in a non-drying cabinet is not operationally feasible). Hatches are provided to pass used endoscopes to the decontamination area without need for clinical staff to leave the patient unattended in the treatment room. Figure 5 assumes that the staffing arrangements in place allow for a dedicated decontamination team.

1.37 In all cases, the layout design should take account of the requirement at multiple stages in the decontamination and use process to record the identity of the endoscope for tracking and trace purposes (see 'Tracking, traceability and audit trail' in the 'Operational management' volume).

## Design of an endoscope reprocessing unit for a local unit or small hospital

1.38 The problems of operating a decontamination room in a small healthcare facility have several major differences to those of larger units where there is more space and separation of defined duties.

1.39 If a new unit is to be designed, the space required for patient services, waiting room, operating room and reception will form only part of the department. Space will also need to be allocated for staff changing areas, staff room, store, cleaning cupboards and offices. The decontamination area will require careful consideration to include the items listed for large endoscopy units. Consideration should also be given to the infection control policies for the healthcare organisation concerned.

1.40 The principles of Health Building Note 13 – 'Sterile services department' should be used for room finishes and standards.

1.41 An assessment of risk from the ventilation system should be carried out and other considerations taken into account (for example, risks from lower gastrointestinal endoscopy).

- 1.42 It is important that the endoscope decontamination area is given sufficient space to carry out high quality work safely for both patients and staff.

should be considered. For single machines it is usually possible to move them to allow access for an engineer. For built-in EWDs, this facility is not available; therefore, engineering access should be designed from the dirty side of the machine.

## Access to engineering services

- 1.43 Accessing services behind and/or to the side of the EWD and the maintenance needs of the EWD

**Table 2 Checklist of engineering considerations when setting up a new endoscope reprocessing unit or upgrading an existing room (this table should be read in conjunction with Chapter 3, 'Engineering services')**

<p><b>Water supply</b> (see Chapter 2, 'Water quality and water treatment')</p> <ul style="list-style-type: none"> <li>Analyse the unit's cold water supply for hardness, conductivity, total organic carbon (TOC) and total viable count (TVC) (see Table 3 in this volume and 'Total viable count' in the 'Testing methods' volume).</li> <li>Determine the source of the water supply (for example, local tank supply or directly from town mains); the level of residual chlorine is important as it can destroy reverse osmosis (RO) membranes.</li> <li>Obtain water hardness and chlorine data over 12 months if possible to give a guide to the processing plant required for water treatment (note: the water supply company should be able to provide this data for water supplied to the site boundary/meter).</li> <li>Determine the pressure, temperature and flow of the water supply; will it match the EWD requirements when all equipment is operating?</li> <li>Determine the treatment needed for final rinse-water (see Chapter 2, 'Water quality and water treatment')</li> <li>Determine whether the EWD selected requires more than one water inlet; if so, what are the qualities and quantities required?</li> <li>If RO is selected as the water treatment, where will the equipment be housed? Is there space for the water storage tank? Will the floor stand the weight?</li> <li>If RO water is to be distributed to several EWDs, specify the type and quality of pipe material (see paragraph 2.72, 'Pipework').</li> <li>How will treated water be routinely monitored?</li> <li>If filtration, external to the EWD, forms part of the water system, how will the filters be disinfected/replaced, and how often?</li> <li>Conduct audit of water supply system from point of entry to hospital to point of use.</li> </ul>
<p><b>Drains</b></p> <ul style="list-style-type: none"> <li>The position of drains in the floor of a room will, to a degree, dictate where the EWDs can be sited. Therefore it is important to establish the ideal position for the EWDs at an early stage of design to allow the drains to be sited correctly. To move drains can be a major problem, so care in their position is important.</li> <li>Drains from EWDs should be sealed within the room and vented to the outside to prevent noxious gases entering the work area.</li> <li>Check that the drainpipe diameter is sufficient to carry effluent when all equipment is operating.</li> </ul>
<p><b>Ventilation</b></p> <ul style="list-style-type: none"> <li>Check ventilation (air changes per hour) in the decontamination room for the purposes of staff comfort and removal of fumes or smells.</li> <li>Check whether ventilation is to be provided in the chemical storage area.</li> </ul>
<p><b>Electrical services</b></p> <ul style="list-style-type: none"> <li>Check the electrical services required by the EWD. Does the decontamination room's electrical supply match the requirements?</li> <li>Will a three-phase supply be required?</li> <li>Does the current carrying capacity of the decontamination room's electrical supply match the needs of the electrical load when all electrical equipment is working at the same time?</li> <li>Are the electrical shut-off switches conveniently sited?</li> </ul>

**Throughput/workload**

- What will be the daily maximum throughput of endoscopes expected over the next five years? Consider additional factors in the possible use of the decontamination facility by other specialties (e.g. bronchoscopy, flexible cystoscopy) and procedures performed outside the unit (e.g. in X-ray rooms or operating suites).
- Based on throughput, are there enough flexible endoscopes to provide a reliable service?
- From the throughput data, calculate the number of EWDs required.
- The time-out for weekly testing should be subtracted from the number of EWD cycles available (at least one cycle per machine). Also allow for quarterly testing of up to one day, and annual testing of up to three days per EWD. The total time for testing and maintenance may be as much as 40% of the operational time.
- The time-out for machine maintenance should be subtracted from the EWD cycles available.
- Details of throughput are given in 'Choice and procurement of an EWD for flexible endoscopes' (in the 'Operational management' volume).

**Choice of endoscope washer-disinfector (EWD)**

(see 'Choice and procurement of an EWD for flexible endoscopes' in the 'Operational management' volume)

- Examine the type-test data from the short-listed EWD manufacturers. This will allow a fair comparison of machines (see Table 1 in 'Schedule of type tests and works tests' (in the 'Validation and verification' volume)).
- Check that access to the EWD chamber will allow staff to easily operate the EWD without risk to themselves, EWD or endoscope.
- It is essential to ensure there is sufficient space around the machine for access by service engineers to carry out maintenance and testing.
- Check that, when making connections to an endoscope, it is easy and not prone to errors of leaking connectors or wrong identification.

**Tracking and traceability**

- Can a stand-alone tracking and traceability system be connected to the EWD selected?
- Can the tracking and traceability system selected include loan endoscopes?

The 'Tracking, traceability and audit trail' section (in the 'Operational management' volume) gives suggestions on traceability records, audit history and a list of equipment required for computer tracking.

**Decontamination room layout**

- If possible, use two rooms: one for the receipt of dirty endoscopes; and one for manipulation and storage of clean endoscopes.
- If only a single room is available, design the elements so that a flow from dirty to clean is clearly defined.
- Staff training is essential to underline the importance of cross-contamination during endoscope decontamination and storage.
- Within the decontamination area, only include the essential equipment required to clean and treat endoscopes. If possible, water-supply equipment should be housed in a separate room.
- Allow sufficient storage for single-use items and other spares and connectors etc.
- Allow for the storage of decontaminated endoscopes in a clean environment, preferably a drying cabinet.
- Make sure endoscopes are stored securely when the unit is unmanned.
- If electronically-generated peracetic acid is selected as the disinfection chemical, allowance may be required to house the generator in the decontamination room.
- If RO-treated water is required, the unit may need to be installed in the decontamination room.
- If possible, store concentrated chemicals for the EWD in a secure chemical cabinet sited in a safe place.
- Position a spills kit near to the EWDs, but not in the same room.
- Work out the decontamination method for trolleys and transportation devices.

See **Figures 2–5** in 'Example layouts'

## 2 Water quality and water treatment

### Summary for commissioners and quality inspectors

The role of water use during the processing of flexible endoscopes is covered in this section. In particular, the quality of the final rinse-water is discussed in detail with recommendations for the upper limits of certain chemicals, organic matter and bacteria. Guidance is given on water treatment options, depending on the water source. As water storage and biofilm have a great influence on the quality of the final rinse-water, guidance on these subjects is included.

Where a service is provided for a broad range of clinical applications, risk considerations should reflect hazard to the most at-risk patient group.

### Water quality

2.1 Water is used for several purposes in an EWD:

- initial rinse-water;
- intermediate rinse-water;
- final rinse-water;
- as a diluent for chemicals.

### Initial and intermediate rinse stages

2.2 For acceptable hardness levels, see [Table 3](#).

2.3 The intermediate rinse stage between cleaning and disinfection may be omitted if the disinfectant and cleaning agents are known to be compatible and the disinfectant preparation is used only for a single cycle.

2.4 The quality of the intermediate rinse-water is not as critical as the final rinse; therefore the EWD may have a separate water inlet for this grade of water. **It is important during installation to make sure the correct grade of water is supplied to the correct connection on the EWD.**

2.5 Hardness may be an important parameter when examining water supply to the rinse stages. The

manufacturer's specifications should be consulted for the detergent to be used. Advice of the water supplier should be sought where appropriate.

### Final rinse-water

2.6 The grade of water used for the final rinse should be high, as some residual water from a reprocessed endoscope will be transferred into the patient (endoscopes are not dry at the end of an EWD cycle unless stored in a drying cabinet). Therefore any residual water should not harm the patient. This is important in terms of ensuring a satisfactory patient experience of care. For practical purposes, the levels of contaminants described for potable water are sufficient unless an endoscope is to be used in a normally sterile area of the body. Therefore the final rinse-water should not contain any harmful chemicals or organisms. Table 3 (this volume) and Table 2 (of the 'Testing methods' volume) give details of the maximum levels of specific chemicals and organisms suitable for final rinse-water. The level of purity is also described in BS EN ISO 15883-1.

### Note

Final-rinse residual water could be present when samples are taken. If this water is contaminated with environmental mycobacteria, these organisms will appear similar to *Mycobacterium tuberculosis* in tissue and may cause misdiagnosis.

### Chemical process residues

2.7 The level of chemical process residues may be of concern depending on the chemical additives and quality of water used during the cycle. Flexible endoscopes come into contact with mucus membranes or internal body tissues during use. In addition, if hard final rinse-water is used, this may damage the EWD and the flexible endoscope.

2.8 The chemical additives used during the process (detergents etc) may not be completely removed by the rinsing process. The residual level that may be

tolerated will depend upon the nature of the chemical. The supplier of any chemical agent used should provide data on the composition of the chemical agent and the biocompatibility of components of the chemical agent. Suppliers should also provide details of the detection method used to determine whether processed items are free from residuals at the specified levels.

- 2.9 Some EWD process cycles add disinfectant to the final rinse-water to kill any contaminating organisms. The level of disinfectant at this stage should be shown to be non-toxic to patients. In addition, the EWD manufacturer should supply data detailing a neutralising chemical that will neutralise the disinfectant ready for microbiological analysis. The sample of the final rinse-water quality should be as given in this CFPP.

#### *How is quality achieved?*

- 2.10 Two of the most commonly used methods of providing water of the quality required for the final rinse are RO or other filtration methods. Where active processes are used, it is important that these are monitored and the equipment is maintained.

- 2.11 The nature and extent of treatment will depend in part on the quality of the local water supply. Therefore when a new installation is being planned, analysis of the water supply will provide a useful guide for the plant and equipment required to treat the water (see [Figure 6](#)) and may include at least the following steps:

- water softeners;
- pre-filtration to remove larger particulate matter (this may require one or two filtration stages but the final stage should be with a filter that will retain particles of 5 µm or larger) (see [Table 3](#));
- filtration through pre-filter and a bacteria-retentive filter (0.22 µm);
- water deionisation;
- RO;
- addition of non-toxic disinfectant.

- 2.12 For filtration, the operating system may include:

- means to monitor the integrity of the filter or warn of failure (for example, measurement of pressure differentials);
- means to disinfect the filter and the downstream water distribution system at the start of the working day. In addition, self-disinfection

should be set up on the EWD to occur using a timer during periods when the EWD is not used. This should preferably be by exposure to moist heat;

- means to maintain the filter with a constant flow of water (not left wet in static water);
  - means to inhibit microbial growth in water in the storage and distribution system downstream of the filter;
  - means to measure the addition of disinfectant, if used.
- 2.13 Owing to pressures on water resources, water supply companies may vary the source of water abstraction or alter the distribution supply network; therefore, analysis of water supplied over time should be obtained to ensure the range of water quality likely to be encountered can be determined. The sampling point should be as close to the endoscope decontamination site as possible.
- 2.14 If heated water storage is used, it will be necessary to cool the water supplied to the EWD to ensure that the endoscope(s) are not damaged by exposure to too high a temperature (above 60°C).

#### **Water used to dilute chemicals**

- 2.15 The grade of water used to dilute chemicals in an EWD should not affect the efficacy of the chemicals. Detergent, when diluted, should provide a good cleaning effect. Disinfectants, when diluted, should kill contaminating organisms. The hardness level shown in [Table 3](#) should be used for this purpose.

#### **Key factors affecting the quality of water**

- 2.16 Knowledge of the mains water characteristics supplied to endoscope decontamination unit can be very useful. In many modern hospitals the water may be supplied via a storage tank. It is possible that this tank could give rise to high bacterial number or high chlorine levels. If water treatment is planned for the endoscopy unit these properties can be allowed for. In areas where the mains water is of good quality, and the supply to endoscopy is taken from the incoming main, only a limited treatment may be required to obtain the quality described in this document for final rinse water. To adopt this procedure would meet the requirements of Best Practice.

Table 3 EWD water chemistry requirements

Application	Requirement
Initial flush	Hardness less than 200 mg/L CaCO <sub>3</sub>
Intermediate flush	Hardness less than 200 mg/L CaCO <sub>3</sub>
Water for diluting disinfectants and detergents	Hardness less than 50 mg/L CaCO <sub>3</sub>
Final rinse-water (see also Table 1 in 'Water system' in the 'Testing methods' volume)	Hardness less than 50 mg/L CaCO <sub>3</sub> TOC less than 1 mg/L Conductivity less than 40 µS/cm, unless disinfectant added

Note: If any of the above parameters for the final rinse-water are above the stated limits, additional water analysis will be required to determine the source of the problem (for example, pH, chloride, heavy metals etc).

The criteria and parameter limitations for other contaminants including salts not listed in this Table should accord with the rolling revision of the WHO guidelines for drinking water quality. In light of the use of variable supply quality through the recently established national water grid, it is appropriate for providers to periodically discuss this issue with their water supplier.

Tests for **hardness** and **electrical conductivity** are detailed in the 'Testing methods' volume.

- 2.17 The number, nature and quality of water supplies required are dependent on the size and type of EWD.
- 2.18 The quality of water (see Table 3 of this volume and Table 2 in the 'Testing methods' volume) used at all stages in the decontamination process is critical to the successful outcome of the process. Factors include:
- water hardness;
  - temperature;
  - ionic contaminants (for example heavy metals, halides, phosphates and silicates);
  - microbial contamination;
  - water deposits;
  - bacterial endotoxins
  - TOC.

## Water hardness

- 2.19 Hard water is caused by the presence of dissolved salts of alkaline earth metals (principally calcium, magnesium, barium and strontium), which have low solubilities. Although a guide level of calcium equivalent is given in this document, additional data will be required to determine if use of a particular water supply will result in deposits forming on processed items. Many detergents and disinfectants are seriously impaired in their activity by hard water (see Table 3).
- 2.20 Using hard water in the final rinse stages of an EWD cycle is one of the major causes of deposits on load items. These deposits are not only unsightly and an unwelcome contaminant, but act as a focus for soiling and recontamination of the item in use. Such deposits may seriously impair the utility of the endoscope, particularly the optical system. Hard water may cause scaling on the edges of spray nozzles even when fed with only cold water. Detergent formulations intended for use only with soft water may give rise to precipitation if used with hard water. If these products are used diluted with hard water in an EWD, serious damage to endoscopes may result.
- 2.21 The presence of hardness salts in water seriously impairs the efficiency of most detergents and disinfectants. If the use of hard water is unavoidable, it will be essential to use process chemicals that contain sequestering agents. This adds considerably to the cost of the process.

## Note

Some EWDs are fitted with integral water treatment systems that are designed to keep the fittings hygienic and the water clean.

## Temperature

- 2.22 The temperature at which water is supplied to each stage of the process has a major effect on the efficacy of the process. Water at too high a temperature during the initial flushing stage may lead to the coagulation of proteins and thus serve to "fix" proteinaceous soil to the surface of the load items. The inflowing water should be maintained at a temperature lower enough to preclude the occurrence of protein coagulation.
- 2.23 Water for the initial flushing stage should be supplied from a cold supply. Many EWDs will shut down if the supply water approaches 30°C. Water

for other stages may be supplied from a different source and may be warm when the cycle has an elevated temperature stage. Manufacturers will advise on the temperatures required for the detergent and disinfectant.

- 2.24 The activity rate of chemical disinfectants generally increases with increased temperature. Water at too low a temperature during the washing stage of the cycle will often impair the ability of detergents used to remove soils composed largely of fats, oils or grease, and will cause failure to achieve the required microbial inactivation. However, too high a temperature with particular compounds can lead to degradation of the active components, evolution of toxic vapours or damage to the endoscopes being processed.
- 2.25 The maximum temperature of rinse-water should be compatible with the items being processed; flexible endoscopes are temperature-sensitive and may be damaged by temperatures above 60°C.

### Ionic contaminants

- 2.26 Water used in the cleaning and disinfection of flexible endoscopes should have a chloride concentration between 0 and 120 mg/L chlorine to avoid the risk of corrosion. Chloride concentrations greater than 240 mg/L can cause pitting of some stainless steel and plastic components.
- 2.27 Water used for the final rinse should have a chlorine level no higher than 10 mg/L. Chlorine levels exceeding this level should be reduced using a carbon filter. (In some EWDs, a chlorine compound is added to the final rinse-water to prevent microbial contamination.)
- 2.28 A measure of the ionic contamination of water can be gained by the measurement of conductivity (Table 3). If it is suspected that specific chemicals may contaminate the water source, other tests for individual compounds should be carried out.
- 2.29 For final rinse-water that contains a disinfectant, conductivity may be greater than 40 µS/cm. Guidance from the manufacturer will be required to ensure damage to flexible endoscopes does not occur with multiple use.
- 2.29 Some EWDs incorporate a disinfectant that will have a chloride concentration greater than 120 mg/L. Assurance from the manufacturer should be obtained regarding materials compatibility, both for the EWD and the endoscopes in use.

### Microbial contamination

- 2.30 The purpose of the decontamination process is to remove soiling and reduce the microbial contamination to an acceptable level for the intended use of the items to be processed. The water used at each stage of the EWD process cycle should not increase the bioburden of the load items.
- 2.31 Flexible endoscopes are used without further decontamination processing. The nature and extent of the microbial contamination in the final rinse-water should not present a potential hazard to the patient, either through infection or by leading to an erroneous diagnosis (see Table 3). Appropriate treatment to control or reduce the microbial contamination in water may be required (see paragraph 2.44, 'Water treatment options').

### Deposits from water

- 2.32 Mains water may well contain deposits originating from the water treatment plant or distribution system. Water used in an EWD should be clear and colourless.
- 2.33 Water deposits should be removed by filtration; otherwise they may affect endoscope cleaning and disinfectant efficacy, and leave deposits inside endoscopes on completion of the process cycle.
- 2.34 Pre-treatment should be used where required to protect RO units.

### Bacterial endotoxins

- 2.35 Bacterial endotoxins are thermostable toxic compounds derived from the cell walls of bacteria which, when introduced into the human body, can cause a fever-like reaction and other adverse effects. They are not readily inactivated by chemicals or removed by bacteria-retentive filters. Control of endotoxin exposure is important to outcomes and the care experience.
- 2.36 EWD final rinse-water should not contain more than 30 endotoxin units/ml. Above this level there is a small risk that the toxin may affect the patient after some procedures. Routine endotoxin testing is therefore not required unless there is evidence of a major water supply problem indicated by the TVC and TOC results (see Table 3 in this volume and Table 2 in the 'Testing methods' volume).
- 2.37 The identification of bacterial species is advised and the results presented to the microbiologist or infection control doctor for consideration. This

information may aid identification of the contamination source and assist with any subsequent advice. The presence of *Pseudomonas* spp. may have direct patient-health implications (see note to Table 2 in the 'Testing methods' volume).

- 2.38 For endoscopy procedures that require very low bioburden final rinse-water (for example endoscopic retrograde cholangiopancreatography (ERCP)), a risk assessment is recommended.

### Total organic carbon (TOC)

- 2.39 Where the risk assessment indicates TOC testing is used as a risk control indicator for the predisposition of biofilm formation, testing will be required at intervals that reflect local risk assessments.
- 2.40 If the EWD's self-disinfection cycle is demonstrated to be effective (for example by TVC monitoring), TOC testing will not be required.

### Legionella and *Pseudomonas aeruginosa*

- 2.41 The presence of legionella in the final rinse-water of an EWD is very unlikely, but possible. Legionella are normally found in contaminated water in association with other organisms and the presence of biofilm. The laboratory detection of legionella is in the order of 100 legionella per litre; therefore, at least a 1 L sample is required by the test laboratory.
- 2.42 Subject to risk assessment, testing the final rinse-water for legionella may not be required. If the detection of legionella is considered necessary, the method described in Health Technical Memorandum 04-01 should be applied.
- 2.43 *Pseudomonas aeruginosa* has been reported to colonise some taps both in wash-hand basins and sinks used for cleaning or general tasks (see DH guidance for further advice).

### Water treatment options

- 2.44 There are generally six methods of water treatment available for use on water supplies to be used in EWDs. These can be used as individual treatments or in combination:
- water softeners;
  - water deionisers;
  - distillation;

- RO;
- filtration;
- disinfectant addition.

### Water softeners

- 2.45 Water softeners, or "base-exchange" (ion exchange) softeners, consist of an ion exchange column containing a strong cation resin in the sodium form. Calcium and magnesium ions in the water are replaced by sodium ions. The column may be regenerated by treatment with a solution of common salt (sodium chloride). These units allow bacterial growth so may cause a significant increase in the microbial content of the water.
- 2.46 Sodium salts, which remain after softening, do not readily form hard deposits to foul heat exchangers or spray nozzles, but if used as the final rinse, they will leave white deposits on the load items as they dry.
- 2.47 Water softeners are simple to operate with an automated in-line system, will handle water with varying levels of hardness, and are safe to regenerate. After regeneration, however, high levels of chloride ions may be present in the initial output from the softener, which should be run to waste.

### Integral water softener

- 2.48 EWDs are available with built-in base-exchange water softeners. Water softeners should be chosen based on the total demand of softened water in the unit.
- 2.49 In common with other water treatment systems, the base-exchange softener needs to run to a minimum volume of outflow if the required water quality is to be achieved. The manufacturer of the treatment plant should specify this volume. The output from the softener should be to a water tank, and the volume demanded each time additional water is fed to the tank should exceed the minimum flow (see Health Technical Memorandum 04-01 for guidance on water storage).

### Water deionisers

- 2.50 Deionisation or demineralisation systems can remove virtually all the dissolved ionic material by ion-exchange using a combination of cation and anion exchange resins either in a single column (mixed bed) or in a separate column. Their use for



treating the final rinse-water of an EWD is not recommended.

- 2.51 Operating costs of mixed bed deionisers are usually higher than those for two-stage systems.
- 2.52 Routine maintenance (regeneration) of deionisation and demineralisation systems requires the use of a strong acid (hydrochloric acid) and a strong alkali (sodium hydroxide). For most types of installation, an exchange column service is available from the water treatment suppliers. The maintenance of these systems in line with the manufacturer's requirements is essential to safeguard output quality.
- 2.53 Deionised water may become contaminated with microorganisms and the resin column colonised. Deionised water should not be used for the final rinse of products intended for invasive use without further decontamination processing by heating, filtration etc. It is essential that a risk assessment in this area and related local policy establish safe water supply appropriate for each stage of the process.
- 2.54 For a given output volume, the initial cost of providing deionisation equipment will be lower than for RO. However, the inconvenience and cost of the regeneration process for deionisers, and the better microbial quality of the RO process, makes RO the preferred option.
- 2.55 The use of deionisation for EWD water is not common, since EWDs are only suitable for a water supply low in inorganic contaminants (otherwise the exchange or regeneration of cartridges is too frequent).

### Distillation

- 2.56 Distilled water may equal or exceed the purity of RO water but, despite the relatively low capital cost of the necessary plant, is very expensive to produce due to the high energy usage.

### Reverse osmosis (RO)

- 2.57 RO treatment plants remove almost all dissolved inorganic contaminants by passing the water, under pressure, through a semi-permeable membrane against an osmotic gradient. The process will also remove a high proportion of organic material, bacterial endotoxins and microorganisms. Some RO units are fitted with a final 0.2 µm filter to control bacterial numbers.
- 2.58 The initial capital cost of an RO plant is generally higher than for a deionisation system supplying a

similar volume of water, but operational costs are lower. The water has a low TOC level and microbial population. Measures are required to maintain the microbial quality of water during storage and distribution. The retention of this water quality requires a high level of understanding and maintenance.

- 2.59 The wastewater produced by properly RO plant may be designated as grey and reused appropriately.
- 2.60 Issues to be considered when installing RO systems include:
  - An RO system removes bacteria, endotoxins and approximately 95% of chemical contaminants.
  - The system and associated pipework need to be sanitised regularly.
  - The system provides processed water over a long period with minimal maintenance.
  - Routine maintenance and membrane replacement are very important.
  - The system provides water quality suitable for diluting EWD chemicals and final rinse.
  - The system usually requires a carbon filter to be fitted ahead of the RO unit to remove traces of chlorine from the water supply.
  - RO units use large volumes of water, much going to waste, which can be used as grey water.
  - Selecting an RO system will depend on the geographical area of the water source and its quality (see Figure 6 below).
  - If the supply water is hard, a softening system will be required ahead of the RO unit.
  - Water storage is required, as RO units supply moderate volumes of water over a long period. EWDs need large volumes of water quickly during various stages of the cycle.

### Filtration

- 2.61 When water is treated by filtration (for example, through a 0.22 µm filter to remove microbial contaminants), rigorous controls are needed to ensure that the system works effectively. This should include:
  - either maintaining the pressure drop across the filter throughout its working life – a decrease in differential pressure being cause for rejection of the process cycle and a change of filter – or a bubble point test (see BS 1752, ISO 4793). In

the event of concerns in this area, a service agent should be consulted;

- a continuous recirculation system for RO water supplies. For a bank of filters, intermittent chemical disinfection is appropriate to prevent a bioburden build-up;
- treatment of the circulating water to ensure that proliferation of microbial contamination is inhibited either by use of elevated temperature (for example, greater than 60°C), filtration through a suitable fine filter or by ultraviolet irradiation (wavelength  $260 \pm 10$  nm;  $>2$  J/m<sup>2</sup>) or chemical biocide.

**Note**

Ultraviolet irradiation will only kill planktonic microbes; it has little effect on biofilm.

**Disinfectant addition**

2.62 If a chlorine-based disinfectant is used, some providers are allowing a non-toxic disinfectant to

be present in the final rinse-water (see the ‘Process chemicals’ section in the ‘Operational management’ volume). Confirmation is required to show these chemicals, in the concentrations used, are not toxic to the patient. Residual chlorine remaining in a reprocessed endoscope may reduce the possibility of biofilm formation and growth of contaminants.

**Water treatment plant**

2.63 Despite the cost involved, treating water from the public supply is usually cost-effective. It is important that any water treatment plant is designed to be self-disinfecting with a system built-in to pump disinfectant around the complete treatment circuit on a regular basis (for example, during the EWD’s self-disinfection stage). A 5 µm filter should be fitted as a pre-treatment before an RO unit.

**Backflow prevention**

The water supplied to the EWD should comply with the Water Fittings (Water Supply) Regulations.

Figure 6 Selection of water treatment systems for EWD final rinse

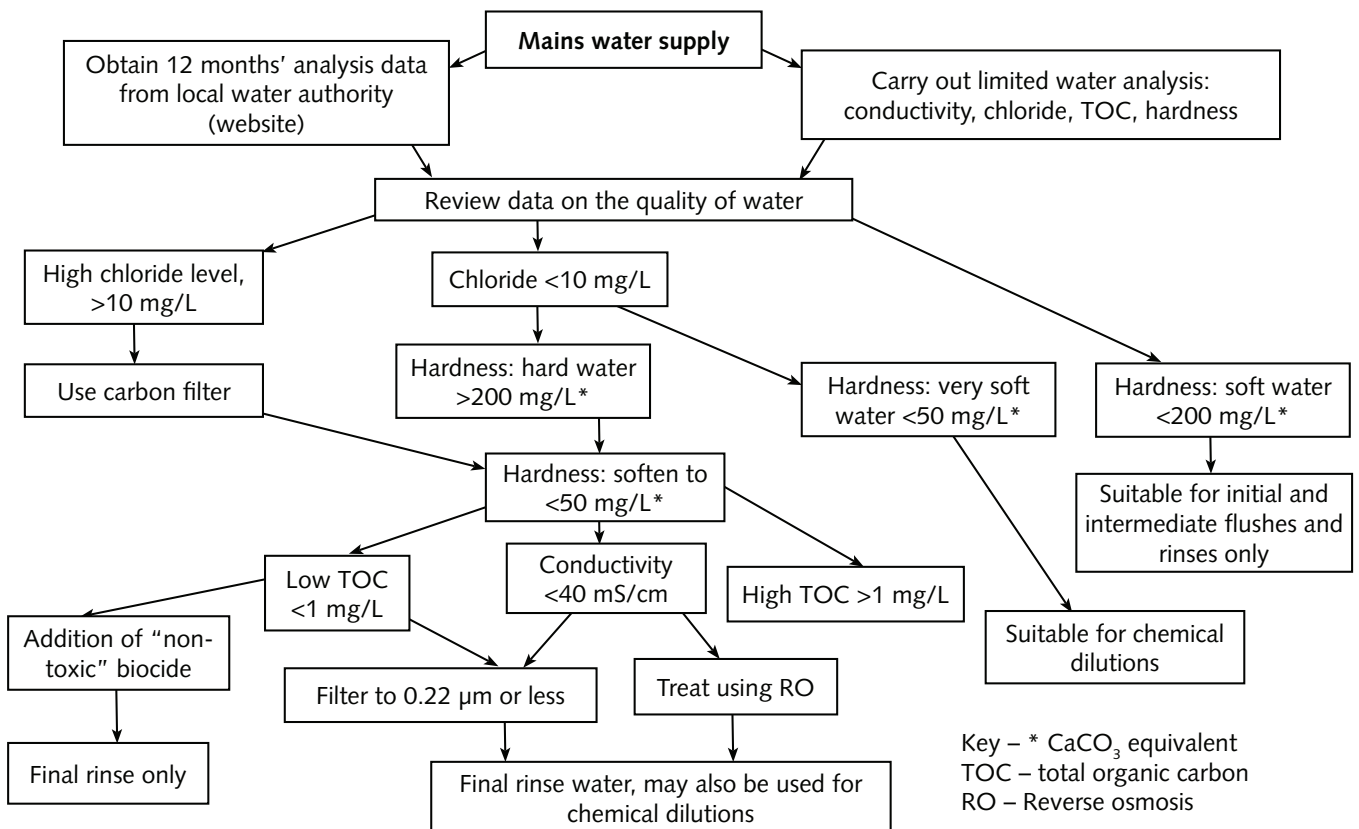

## Tests for purity levels

### Chemical purity

2.64 The chemical purity of water used in an EWD is not critical as long as the quality is better than that of potable water with a hardness level below 200 mg/L CaCO<sub>3</sub> (except for chemical dilutions and final rinse where a maximum hardness of 50 mg/L CaCO<sub>3</sub> is acceptable). To determine whether the water supply is suitable for an EWD's final rinse-water, a conductivity test is suitable (see paragraph 2.16, 'Key factors affecting the quality of water'). Where elevated process temperatures are used, particular care should be taken over contaminant levels; the equipment manufacturers should be consulted.

### Organic purity

2.65 Organic compounds dissolved in water may cause a problem, if in high levels, when mixed with detergents and disinfectants. In particular, high levels of organic compounds can cause a detergent to foam, reducing its cleaning effect.

2.66 A general measure of dissolved TOC is useful as a guide to water contamination. Organic compounds may be present in water at source due to the supply catchment area. In addition, organic compounds will be added to water if filters become overgrown with organisms. Therefore, a TOC test can provide a useful guide to the state of the final rinse-water: a maximum TOC of 1 mg/L is acceptable.

### Microbial purity

2.67 Potable water from the public supply has a low microbial content and be free from pathogenic organisms, but may contain organisms that could cause opportunistic infections in immunocompromised patients if allowed to grow to high numbers.

2.68 The microbial content may increase considerably in intercepting tanks and cisterns.

2.69 Attention is drawn to the requirement under the the Health and Safety Executive's Approved Code of Practice on legionella (L8) that water in intercepting tanks (not RO holding tanks) should be stored below 20°C or above 60°C (see also Health Technical Memorandum 04-01).

2.70 Water stored at 60°C or above may be assumed not to have a proliferating microbial population.

2.71 EWD final rinse-water should be provided by a water treatment system that generates bacteria-free or sterile water. A small volume of this water may remain in the endoscope at the point of use. Just before use, a surgeon may inject the endoscope with sterile water before starting a procedure to confirm all the lumens are clear.

## Pipework

2.72 The design of the pipework, tanks and sanitary fittings should avoid dead-legs and an area where microbial growth may proliferate is critical to the maintenance of the system from microbial contamination (see Health Technical Memorandum 04-01).

2.73 Pipework used to supply the various grades of water should be appropriate to the quality of water carried. Stainless steel or suitable uPVC pipes are preferred for all qualities of purified water (see BS 6920-2.4).

2.74 Fittings and pipe connectors used to deliver the final rinse-water should have minimal dead space and be drained at the end of the process cycle.

2.75 The pipework, valves and pumps through which final rinse-water will pass should be subjected to an appropriate frequent sterilization/disinfection process. This is normally achieved by self-disinfection carried out daily.

2.76 Certain types of plastic pipe and tank material may, when first installed, give off organic carbon. Joining compounds used on some plastic pipework may also give a rise in TOC levels. Therefore, TOC measurements on new installations should be repeated over the commissioning period.

2.77 The growth of organisms in water is enhanced by the presence of organic carbon, which is used as a nutrient source. Biofilm (see paragraph 2.79, 'Biofilm formation') often forms on plastic surfaces due to the presence of carbon.

2.78 For pipework and tanks, stainless steel is preferred for this reason. Some systems add biocide to the rinse-water, which will control bacterial growth and the development of biofilm (see paragraph 2.79, 'Biofilm formation').

## Biofilm formation

2.79 Biofilm is a layer of growth that forms due to organisms sticking to solid surfaces.

- 2.80 *Pseudomonas* spp. are a common finding in EWDs. If allowed to form, a layer of growth of other organisms will grow over the top of *Pseudomonas* spp., increasing the thickness of the biofilm. Biofilm can be present over the long term and is very adherent to the surface on which it forms. The removal of biofilm takes considerable effort and may require the use of aggressive chemical agents and physical means.
- 2.81 Biofilm can form in the crevices of valves and pipe junctions, particularly plastic. Therefore, the inside of an EWD should have no dead spaces where biofilm can form. A delay in delivery of an EWD after manufacture and testing will allow biofilm to form within the machine. This may require the replacement of all the flexible pipework when first commissioned to allow the bacterial count in the final rinse-water to pass microbiological tests.
- 2.82 The addition of a non-toxic biocide to the final rinse-water may help prevent the formation of biofilm.

## Water supply regulations and services

- 2.83 See Health Technical Memorandum 04-01 and [Chapter 3, 'Engineering services'](#).

## 3 Engineering services

### Summary for commissioners and quality inspectors

Engineering aspects of each service supplied to an EWD are discussed. In addition, guidance is included on the particular aspects of these services that apply to EWD installation, operation and maintenance. Attention is drawn to the information provided by EWD manufacturers on the engineering services required for EWD operation. Guidance is also provided on ventilation, both in the decontamination suite and in relation to the EWD.

Quality inspectorates should ensure that sound arrangements are in place to ensure servicing in keeping with the guidance provided here.

- 3.1 An EWD will require the following services: electricity, water, drainage, ventilation and chemical additive (detergent, disinfectant etc) supply. Exceptionally, clean positive pressure air supply may be needed. The manufacturer's product data sheets will show which services are required for each model. It should be determined which of these are available at the proposed site and the capacities of each service. It may be necessary to plan for a new service, which would add significantly to the cost of the installation.
- 3.2 The manufacturer should make clear at an early stage which services will be needed and give detailed requirements for each service (see Table 4).
- 3.3 For most EWDs, the water and drainage services are the most critical although for User comfort and safety the ventilation and extraction system are also important.
- 3.4 If the services are to be installed by a contractor, other than the contractor installing the EWD, care should be taken to ensure that the size and location of terminations are agreed before the contracts are placed.

**Table 4 Information on services to be obtained from the EWD manufacturer**

<b>Electricity</b>
1. number of phases (normally one or three) and whether neutral is required for a three-phase supply;
2. supply voltage and frequency including nominal and acceptable minimum and maximum values;
3. maximum continuous power demand in kilowatts (kW) or kilovolt-amperes (kVA).
<b>Water (for each grade of water required, i.e. hot and cold water, wash and rinse-water, final rinse-water)</b>
1. the acceptable range of supply pressures;
2. the flow at minimum pressure;
3. the volume used per cycle;
4. the acceptable temperature range for incoming water (see 'Water quality and water treatment');
5. confirmation that the supply water is of potable standard (possibly carried out by a third party – see <a href="#">Chapter 2, 'Water quality and water treatment'</a> );
6. the quality of water required when relevant – the maximum permissible hardness expressed as mg/L CaCO <sub>3</sub> (see Chapter 2);
7. the acceptable range of pH (see Chapter 2);
8. the maximum permissible conductivity (see Chapter 2);
9. the maximum acceptable microbial population (see Chapter 2).
<b>Drainage</b>
1. the maximum flow of effluent to the drain;
2. the maximum temperature of the effluent on leaving the EWD;
3. the maximum effective diameter of the discharge orifice from the EWD chamber;
4. the drain and associated system should be sealed to prevent aerosols, splashes, droplets and vapours being released into the room.

*continued overleaf*

### Ventilation

1. if the EWD uses thermal self-disinfection, the peak value during a cycle and the average value throughout a cycle of the heat (in watts) transmitted to the environment when the EWD is operated in still air at an ambient temperature of  $23 \pm 2^\circ\text{C}$ ;
2. ventilation requirements for removal of fumes or gases from hazardous chemicals used in the process;
3. for double-ended EWDs, air passage between wash room and clean room, via openings around the EWDs, should be minimised to limit pressure loss if there is a differential pressure between the wash room and clean room.

### Ancillary equipment

- 3.5 Ancillary equipment, for instance water treatment plant, should whenever practicable be installed and commissioned before validation of the EWD begins.
- 3.6 When the checks on ancillary equipment require the EWD to be in operation, the Competent Person (Decontamination) (CP(D)) should carry them out in cooperation with the contractor for the EWD.
- 3.7 The contractor for the EWD is not responsible for the correct functioning of services and ancillary equipment unless this was agreed in the purchase contract.

### Water services

- 3.8 Water supplies to the EWD may be derived from:
  - mains water supply;
  - the healthcare facility's header tank supply;
  - the healthcare facility's softened supply;
  - local softened water supply;
  - RO water supply.
- 3.9 It is important that the organisation responsible for the EWD water supply is known. Any problems found during installation or operational tests due to the water supply need to be resolved quickly, otherwise commissioning could be delayed.
- 3.10 An analysis of the supply water quality should be carried out at an early stage of upgrading or when designing a new installation (see [paragraph 2.1, 'Water quality'](#)). A request for a copy of the water analysis report from the local water supply company may give the water quality data required. From this data, the design of the water treatment

plant can be made (see [Figure 6](#)). If water supplied to an endoscopy department is stored within the building and treated locally before distribution, information on this treatment will be needed from the estates and facilities department. In addition, knowledge of the supply pipe layout would be useful to determine whether any dead-legs are present.

- 3.11 Some water authorities require a Class A air gap for water supplied to medical devices, even if the water is fed from the healthcare facility's main tank.
- 3.12 EWDs may be supplied with both hot and cold water. When warm water is required as part of the operating cycle, it is generally advantageous to supply hot water to the EWD to dilute with cold water for use, rather than heat cold water to the required temperature within the EWD, as this may reduce cycle time. The quality of water used at all stages in the decontamination process is critical to the successful outcome of the process.
- 3.13 General guidance on EWD water supplies is given throughout [Chapter 2, 'Water quality and water treatment'](#). See also [Table 2](#) for a checklist on water supply.

### Electrical services

- 3.14 The electrical power requirements will depend on a number of factors, such as the type of EWD and the method used to heat water. Some EWDs will need a three-phase supply. The manufacturer should provide details of the type of supply, number of phases, frequency and voltage, with tolerances and loading.
- 3.15 Each EWD should be connected via an isolator. The type of isolator will depend on the nature of the supply and its location. For instance, in some locations exposed to a risk of water spray, the IP rating should be considered.
  - For small EWDs and bench-top EWDs with a maximum current demand not exceeding 13 A on a single-phase supply, isolation may be provided by a switched fused connection unit with a flex outlet. Where several machines are located on the same bench, the connection unit should be labelled to show which machine it is controlling.
  - If a three-phase and neutral supply is required or when the maximum demand from a single-phase supply is more than 13 A, the EWD should be wired directly to an isolator. The

cable from isolator to EWD should be fixed and protected from the effects of heat and water.

- 3.16 Within the loading area, an additional switch should be provided so that the operator can electrically isolate the EWD or group of EWDs in the event of an emergency. The switch should be placed at a convenient height between the normal operating position and the exit door and labelled “Emergency switch for EWDs” to show its function.
- 3.17 For multiple installations, it may be necessary for the switch to control a contactor, which isolates the distribution board supplying the EWDs.
- 3.18 It is not normally necessary for EWDs to be connected to the essential supplies circuit. Exceptions might include the decision to ensure that one EWD within the endoscopy unit remains on the essential supplies circuit. Guidance on the supply of electricity in the event of failure of the normal supply is given in Health Technical Memorandum 06-01 – ‘Electrical services: supply and distribution’.
- 3.19 All electrical installations should conform to the Institution of Engineering and Technology’s (IET) Wiring Regulations (BS 7671). Further guidance is given in Health Technical Memorandum 06-01 ‘Electrical services supply and distribution’ Parts A and B and Health Technical Memorandum 06-02 – ‘Electrical safety guidance for low voltage systems’.

## Drainage

- 3.20 All effluent from an EWD is potentially contaminated and should be disposed of to the main drain.
- 3.21 Effluent may originate from each of the stages of the process, which may include:
- flushing to remove gross contamination;
  - washing with detergent and/or enzymatic cleaners;
  - rinsing, with or without the addition of a neutraliser;
  - chemical disinfection;
  - post-disinfection rinsing;
  - drying.
- 3.22 Effluent from the initial stages [(a) and (b) above] of the process may contain significant concentrations of organic contaminants and potentially infective microorganisms. Effluent from the middle stages [(b), (c) and (d) above] may also contain some organic contaminants and potentially infective microorganisms and high concentrations of process chemicals.
- 3.23 Effluent from EWDs should pass via an air break into a tundish or tank before being discharged to drain. The air break should be preserved at all times to prevent the EWD and its associated pipework being contaminated by reverse flow from the drainage system.
- 3.24 When a tank supplies water to a pump on the EWD, the overflow discharge from the tank should also include an air break.
- 3.25 The drainage system from the installation should be trapped and designed to pass the flow-rate of water, air and condensed steam specified by the manufacturer, with account taken of the peak output during the operating cycle.
- 3.26 The drainage system should be designed to pass and maintain in suspension the solids removed from the load during the flushing process. The minimum diameter of the drainage system should be greater than the maximum diameter of the most restricted section of the discharge from the EWD chamber.
- 3.27 Means should be provided to prevent, as far as possible, toxic gases being liberated into the atmosphere, particularly into the work area.
- 3.28 If thermal self-disinfection is used, the discharge temperature from a EWD may be as high as 85°C. The materials used for the construction of the discharge system should be chosen to withstand temperatures up to 100°C.
- 3.29 Attention is drawn to the legal requirement (Public Health Act 1936, Paragraph 27) that the maximum temperature of any liquid to be emptied into the public sewer or communicating drain is 43°C. This should be interpreted as referring to the main building connection to the sewer and not to the internal building drain. However, if the installation is in a small medical unit, the drains may well connect directly to the main sewers and will therefore be subject to the temperature restriction.
- 3.30 The drain system will need to withstand the action of chemicals used in the EWD process. RO water, possibly used in the final rinse stage, may corrode materials.

## Hazardous effluents

- 3.31 The discharge of soil from EWDs should be regarded as being no more, but no less, hazardous than the discharge from any other sanitary appliance (for example, a WC).
- 3.32 The discharge of process chemicals, including detergents and disinfectants, may require special attention. The local water company should be consulted before such chemicals are discharged into the drainage system, as it may be necessary to neutralise or inactivate them before discharge.
- 3.33 A sealed and vented drain should be used for the discharge of chemicals with a significant vapour pressure – determined at the maximum attainable temperature of effluent in the drain – which may be hazardous to health or a nuisance. Possible backflow from the drain should be prevented by the inclusion of a check valve and a vacuum breaker. The discharge of toxic gases from the drain system into the work area should be avoided.

## Ventilation

- 3.34 Ventilation of the area near EWDs may be needed to remove excessive heat and humidity, and also vapours from disinfectants such as peracetic acid.
- 3.35 Electrical systems used in ventilation installations should take account of the high levels of humidity that may be discharged and the potential for this to condense within the ventilation system.
- 3.36 All ventilation systems should meet the ventilation requirements of the Workplace (Health, Safety and Welfare) Regulations.
- 3.37 The EWD, including any special ventilation equipment necessary for its safe operation, will be subject to the COSHH Regulations (2002). These regulations introduced controls on biological agents, which are of relevance to purchasers of EWDs.
- 3.38 Detailed guidance on ventilation systems is provided in Health Technical Memorandum 03-01 – ‘Specialised ventilation for healthcare premises’.

### General room ventilation

- 3.39 The ventilation system to an area of endoscope cleaning and EWD loading should be at a pressure below atmospheric.
- 3.40 If the endoscope decontamination area is divided into clean and dirty areas the ventilation system

reference should be designed to Part A of Health Technical Memorandum 03-01, Appendix 2. See also [Table 1](#).

- 3.41 In designing the ventilation system, several factors are of particular importance:
- the provision of adequate airflow to prevent the build-up of toxic gases given off when the EWD lid or door is opened to remove the load;
  - the provision of adequate cooling so that working conditions remain comfortable for staff;
  - correct sizing of the room ventilation system and/or interlocking with extract fans on EWDs and other extraction systems in the area to ensure correct operation of both the room ventilation system and the machine/process specific extraction system(s) when extraction fans on EWDs and/or local extraction is in operation;
  - the air-flow should be from clean to dirty areas.

### EWD ventilation

#### *Air quality*

- 3.42 The quality of air may be critical for some applications, and some EWDs will incorporate appropriate filters. When the purchaser is to be responsible for the provision of filtered air, the CP(D) should ensure that the quality of air available meets the EWD manufacturer’s specification or the requirements given below.
- 3.43 Air that could come into direct contact with the load, such as air used for drying the load or testing the free-passage of lumens, should be oil-free (that is, should have no more than 0.5 mg of oil per cubic metre of free air measured at 1013 mbar and 20°C; see ISO 554), be filtered to an efficiency of at least 95% when tested in accordance with BS 3928 and be free of bacteria (see Health Technical Memorandum 02-01 – ‘Medical gas pipeline systems’).
- 3.44 Air for control purposes should be free of liquid water, filtered to 25 µm (5 µm for precision controls) and lubricated with micro-fog oil particles of 2 µm or less.

#### *Air pressure*

- 3.45 EWDs may run under a slight negative pressure in the chamber to minimise the potential for the



discharge of chemical vapours into the environment.

### *Air extraction system*

- 3.46 EWDs not equipped with an air extraction system may require an extraction device to be mounted above the door or lid to reduce chemical vapours entering the workspace.
- 3.47 The air extracted from EWDs operating a heated self-disinfection stage will normally have a high moisture level during this stage. The extraction system should, therefore, be equipped with a drain to discharge the condensate and should be designed and constructed so that it may be cleaned periodically. The drainage system should be constructed with a continuous fall to discharge, without any upstand at the point of connection to the ventilation system to prevent pooling.
- 3.48 The output from an extraction system may contain chemical vapours and should be discharged away from opened windows, air intake systems, general ventilation extraction systems or where down-draughts occur. It is important that adequate dispersal is achieved and roof-level discharge is preferred. The extract from two or more EWDs should not use common ducting unless provision is made to ensure that there is no risk of cross-connection.
- 3.49 The extraction ductwork connected to the EWD is an efficient transmission system for noise originating within either the EWD or extraction plant. Care is needed in the design and construction of the ducting to ensure that noise does not become a problem. This may require the use of sound attenuators as part of the ductwork design. Additional guidance is given in Part A of Health Technical Memorandum 03-01 and Health Building Note 13.

### **Chemical additives**

- 3.50 Safe storage provision is needed for containers of chemical additives used in the EWD (see 'Safety of EWD chemicals' in the 'Operational management' volume).

### **Infectious materials**

- 3.51 All EWDs have the potential to process infectious materials. The User should therefore ensure that

personnel working on EWDs wear appropriate protective clothing and are fully informed of any hazards that may be present. In case of doubt, the microbiologist should be consulted. External maintenance and test engineers should obtain a permit-to-work before entering the endoscopy unit.

- 3.52 Any test equipment and tools used on an EWD should be regarded as potentially infectious. Therefore such items should be handled with care and be disinfected after use, unless they have been processed by a complete EWD cycle.

### **Engineering services checklist**

- 3.53 Check that the following requirements have been met:
- 1 The engineering services have been installed correctly; they are adequate to meet the demands of the EWD; they do not leak and all necessary isolating valves/switches and test points have been installed.
  - 2 Drains remove effluent effectively when all plant in the vicinity, including the EWD, is connected and operating.
  - 3 The water treatment plant (if fitted) operates correctly and the quality of water supplied for each stage of the process is in accordance with the specification.
  - 4 The provision for storage, handling and connection to the EWD for all process chemicals meets the requirements for safe handling of potentially hazardous chemicals.
  - 5 The exhaust ventilation unit fitted to the EWD is adequate to remove the air evolved from the washing, disinfection, drying and unloading processes.
  - 6 EWDs employing chemicals that are volatile require exhaust ventilation to maintain the environmental concentration below any limit specified for occupational exposure and to ensure that the discharge is to a safe place.
  - 7 Subject to local policy related to throughput, it is recommended that data connection points (ethernet) be provided at carefully considered locations to permit the capture of information for appropriate device tracking (see 'Tracking, traceability and audit trail' in the 'Operational management' volume).

# References

- BS EN ISO 13485.  
Medical Devices Regulations.  
Health and Social Care Act 2008: Code of Practice.  
Carriage of Dangerous Goods and Transportable Pressure Equipment Regulations.  
Health Technical Memorandum 05-03 Part A – ‘General fire safety’.  
Workplace (Health, Safety and Welfare) Regulations.  
Approved Document B.  
CIBSE LG2.  
Health Facilities Note 30 – ‘Infection control in the built environment’.  
Health Building Note 00-10 Part A – ‘Flooring’.  
Health Building Note 00-10 Part B – ‘Walls and ceilings’.  
Health Building Note 00-10 Part C – ‘Sanitary assemblies’.  
Health Building Note 13 – ‘Sterile services department’.  
BS EN ISO 15883-1.  
WHO guidelines for drinking water quality.  
Health Technical Memorandum 04-01 Part A.  
Health Technical Memorandum 04-01 Part B.  
DH guidance on managing *Pseudomonas aeruginosa*.  
BS 1752:1983, ISO 4793:1980.  
Water Supply (Water Fittings) Regulations.  
HSE’s Approved Code of Practice (L8).  
BS 6920-2.4.  
Health Technical Memorandum 06-01 – ‘Electrical services supply and distribution’ Part A.  
Health Technical Memorandum 06-01 – ‘Electrical services supply and distribution’ Part B.  
Health Technical Memorandum 06-02 – ‘Electrical safety guidance for low voltage systems’.  
IET Wiring Regulations (BS 7671).  
Health Technical Memorandum 03-01 – ‘Specialised ventilation for healthcare premises’ Part A.  
Health Technical Memorandum 03-01 – ‘Specialised ventilation for healthcare premises’ Part B.  
Control of Substances Hazardous to Health Regulations (COSHH).  
ISO 554.  
BS 3928.  
Health Technical Memorandum 02-01 – ‘Medical gas pipeline systems’ Part A.  
Health Technical Memorandum 02-01 – ‘Medical gas pipeline systems’ Part B.